

# Springloaded Pressure Regulator

Model – GRT20S

## Description

The GRT20S springloaded pressure regulator reduces the supply pressure on the inlet side to a controlled pressure on the outlet side.

## Specifications

Inlet pressure	50, 280 or 420 bar
Adjustable	0-420 bar - 7 pressure ranges
Connections	3/4" NPT or BSPP
Seat diameter	9,5 mm
Cv / Kv	Cv 1.8 / Kv 1.5

## Fluids

This pressure regulator is suitable for gases and liquids.



## Materials

The regulator is made out of barstock stainless steel material.

Body	ss 316L
Springhousing	ss 316L
Valve	ss 316L
Seat	PCTFE, PEEK or rubber
Valve spring	ss 316
Setspring	ss 302
O-rings / diaphragm	NBR, FKM or EPDM

Other materials available on request.

All metal parts are marked with a traceable batch number. Material certificates are available on request.

## Technical details

- all parts cleaned and degreased
- leak-tight seat design
- all regulators tested before delivery

## Standards

- EN 12516 - design
- EN 12266-1 - testing
- PED 2014/68/EU - SEP (article 4, paragraph 3)
- ATEX 94/9/EC -  II 2G

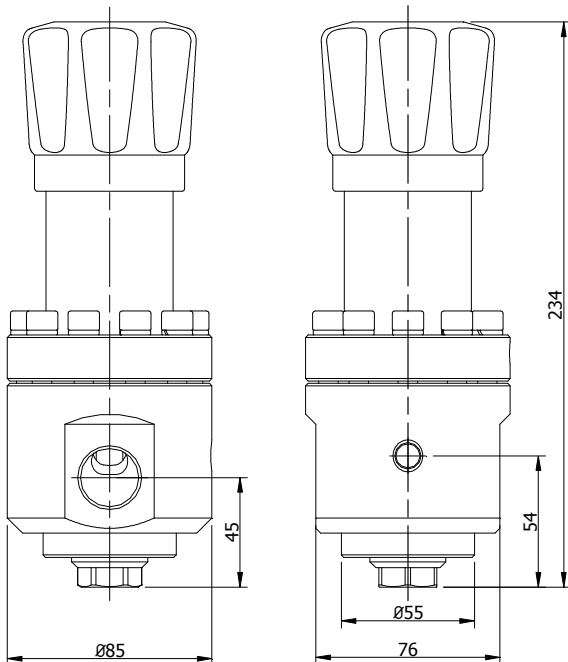

# Springloaded Pressure Regulator

Model – GRT20S

## Options

Many options are available. The most requested options are mentioned below.

## Materials

Regulators can be produced in higher graded materials than stainless steel 316L.

## Seals

Regulators can be equipped with FFKM + PTFE seals. Other compounds for higher or lower temperatures are available.

## NACE - MR 0175

All wetted parts of the regulators can be supplied according to NACE MR 0175, including Inconel X750 valvespring and a NACE report.

## Spare parts

Spare parts kit is available for the regulator. Mention the serial number in case you need spare parts for existing regulators.

## Adjusting the regulator

The regulator comes standard with a knob. The threadpiece below the knob is designed for frequent adjustment.



## Dependency

Character of the regulator is "dependency". The set-pressure will increase, when you have a decreasing inletpressure.

Dependency ratios are listed below.

- range 0-3 bar - 1:350
- range 0-8 bar - 1:350
- range 0-20 bar - 1:350
- range 0-50 bar - 1:110
- range 0-100 bar - 1:55
- range 0-280 bar - 1:20
- range 0-420 bar - 1:14

The balanced valve has a positive effect towards dependency.

## Flow

The regulator has good flow performance over the complete range. Ask for advice if this regulator is the best choice for your application.

Regulators that have a fixed setpoint, can be equipped with a locking cap.



# Springloaded Pressure Regulator

Model – GRT20S

## Internals

The internals of the regulator are important for the performance. The different internals are mentioned below.

### Diaphragm or piston sensing

Diaphragm sensed for pressure ranges  
0-3 bar / 0-8 bar / 0-20 bar

Piston sensed for pressure ranges  
0-50 bar / 0-100 bar / 0-280 bar / 0-420 bar

### Rubber or plastic seated

Rubber seats for design pressure up to 50 bar.  
A rubber seat is less sensitive to dirt.

Plastic seats for design pressure above 50 bar.  
PTFE recommended and seals easy.  
PEEK recommended for liquid and high temperatures.

### Valvespring and setspring

The valvespring gives high spring force to ensure seat-tightness.

The setspring is produced according to our high quality specifications. The low spring rate ensures good performance at high flow.

## Section view

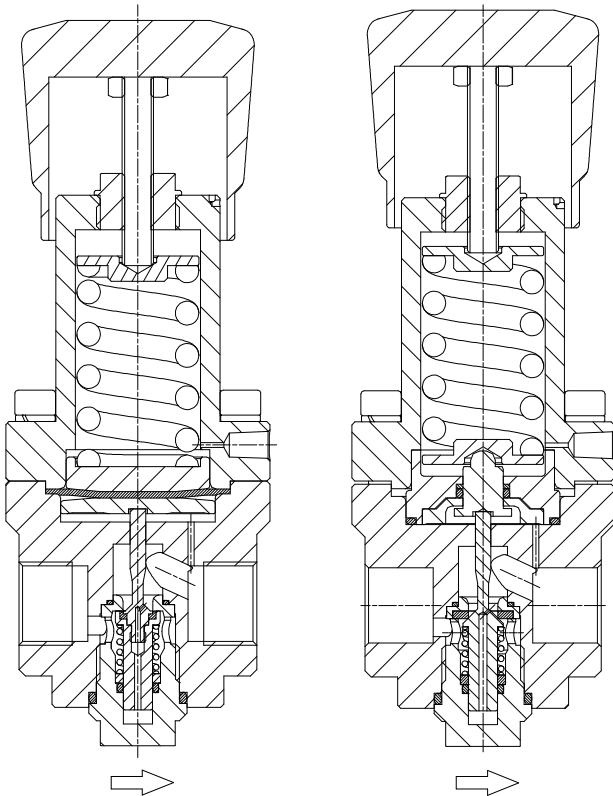

Section view of:  
GRT20S-50B8-SSNN

Section view of:  
GRT20S-420B280-SSNN

## Gaugeports

The regulator has standard one 1/4" NPT gaugeport to measure the controlled setpressure.

Additional 1/4" NPT gaugeports are available, see option G1 and G2 below.

On request other gaugeport options available.

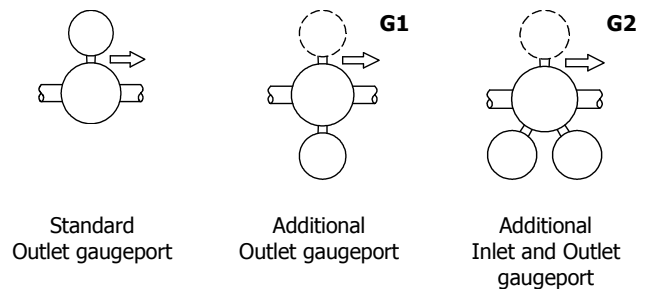

## Gauges

Regulators can be supplied with gauges.

Below ranges are available:

0-4 bar / 0-10 bar / 0-25 bar / 0-60 bar / 0-160 bar /  
0-400 bar / 0-600 bar

- case diameter 63 mm
- internals ss 316
- bottom connection 1/4" NPT

## Mounting

The regulator can be mounted in every position (horizontal / vertical).

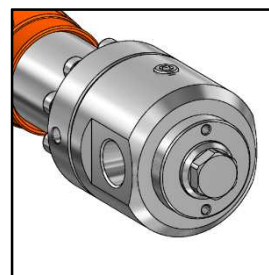

The bottom of the regulator has two mounting holes M6 with 8 mm thread and a C-C distance of 45 mm.

For regulators installed outdoors, make sure that rain cannot enter the springhousing or mount it drainable.

# Springloaded Pressure Regulator

## Model – GRT20S

### Connections

The regulator has threaded connections, designed for compression fittings.

### Line connections

NPT threads according to ANSI B1.20.1

BSPP threads according to ISO 228-1

BSPP ports according to ISO 1179-1

### Springhousing connection

The springhousing has a 1/8" NPT connection.

This connection functions as breathing hole or could be used to pipe away hazardous fluids. Do not plug the connection.

### Design pressures

The design pressure applies for inlet and outletside.

### Seat materials

The seat materials are related to the design pressure.

NBR, FKM or EPDM design pressure up to 50 bar

PCTFE or PEEK design pressure above 50 bar

Depending on temperature or special wishes, the seat material could be different as mentioned above.

### Temperature

The general temperature range of the regulator is -50 / 200 °C, but is often limited due to the used sealing materials.

PCTFE	seat	- 50 / 60 °C
PEEK	seat	- 50 / 200 °C
NBR	seat / seals	- 35 / 130 °C
FKM	seat / seals	- 20 / 200 °C
EPDM	seat / seals	- 50 / 120 °C

## Typenumber explanation

Example : GRT20S - 280N100 - SSKN

model	design pressure	connections	adjustable	material	seat	seals	options
GRT20S	<b>50</b> : 50 bar	<b>N</b> : 3/4" NPT	<b>3</b> : 0-3 bar *	<b>SS</b> SS 316L	<b>N</b> NBR	<b>N</b> NBR	<b>G1</b> one extra gaugeport
	<b>280</b> : 280 bar	<b>B</b> : 3/4" BSPP	<b>8</b> : 0-8 bar		nitrite	nitrite	
	<b>420</b> : 420 bar		<b>20</b> : 0-20 bar		<b>V</b> FKM	<b>V</b> FKM	<b>G2</b> two extra gaugeports
			<b>50</b> : 0-50 bar		viton	viton	
		<b>100</b> : 0-100 bar	<b>E</b> EPDM	<b>E</b> EPDM	<b>L</b> locking cap		
		<b>280</b> : 0-280 bar	<b>K</b> PCTFE				
		<b>420</b> : 0-420 bar		kel-f	<b>xx</b> codes for special option		
				<b>P</b> PEEK			

\* GRT20S-16 with large diaphragm available for higher accuracy in the ranges 0-1 and 0-3 bar

All regulators are marked with a typenumber, a drawingnumber and a unique serialnumber. Dutch Regulators stores the exact configuration of the regulator in the serialnumber.