

Springloaded Pressure Regulator

Model – GRT40S-16

Description

The GRT40S-16 springloaded pressure regulator reduces the supply pressure on the inlet side to a controlled pressure on the outlet side.

Specifications

Inlet pressure	16 bar
Adjustable	0-3 bar
Connections	1 1/2" NPT or 1 1/2" BSPP
Seat diameter	16,5 mm
Cv / Kv	Cv 5.5 / Kv 4.7

Fluids

This pressure regulator is suitable for gases and liquids.



Materials

The regulator is made out of barstock stainless steel material.

Body	ss 316L
Springhousing	ss 316L
Valve	ss 316L
Seat	NBR, FKM or EPDM
Valve spring	ss 316
Setspring	ss 302
O-rings / diaphragm	NBR, FKM or EPDM

Other materials available on request.

All metal parts are marked with a traceable batch number. Material certificates are available on request.

Technical details

- all parts cleaned and degreased
- leak-tight seat design
- all regulators tested before delivery

Standards

- EN 12516 - design
- EN 12266-1 - testing
- PED 2014/68/EU - SEP (article 4, paragraph 3)
- ATEX 2014/34/EU - Ex II 2G

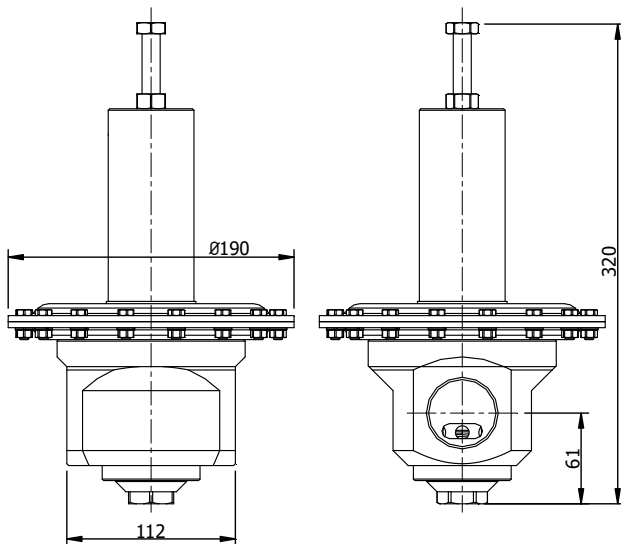

Springloaded Pressure Regulator

Model – GRT40S-16

Options

Many options are available. The most requested options are mentioned below.

Materials

Regulators can be produced in higher graded materials than stainless steel 316L.

NACE - MR 0175

All wetted parts of the regulators can be supplied according to NACE MR 0175, including Inconel X750 valvespring and a NACE report.

Spare parts

Spare parts kit is available for the regulator. Mention the serial number in case you need spare parts for existing regulators.

Dependency

Character of the regulator is "dependency". The set-pressure will increase, when you have a decreasing inletpressure.

Dependency ratios are listed below.

- range 0-1 bar - 1:1700
- range 0-3 bar - 1:1700

The large diaphragm and balanced valve have a positive effect towards dependency.

Flow

The regulator has good flow performance over the complete range. Ask for advice if this regulator is the best choice for your application.

Adjusting the regulator

The regulator comes standard with a setscrew.



Springloaded Pressure Regulator

Model – GRT40S-16

Internals

The internals of the regulator are important for the performance. The different internals are mentioned below.

Diaphragm sensing

The model has a large diaphragm to handle pressures below 3 bar accurately.

Rubber seated

A rubber seat is less sensitive to dirt.

Valvespring and setspring

The valvespring gives high spring force to ensure seat-tightness.

The setspring is produced according to our high quality specifications. The low spring rate ensures good performance at high flow.

Section view

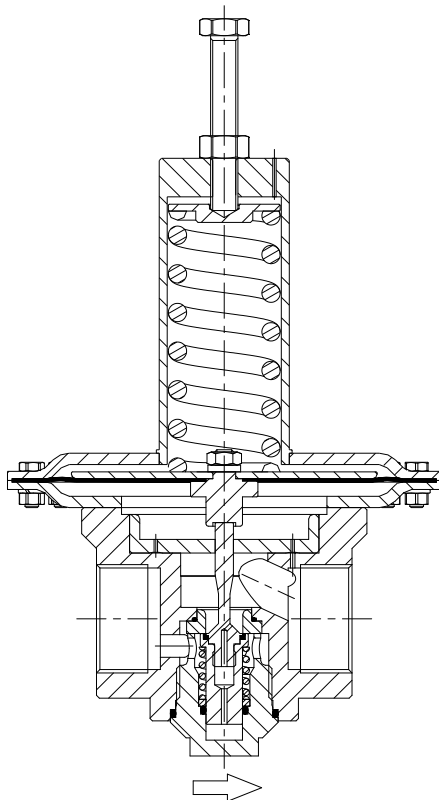

Section view of:
GRT40S-16N1-SSW

Gaugeports

The regulator has standard two 1/4" NPT gaugeports to measure the inlet and outlet pressure.

On request it is possible to have additional gaugeports.

Gauges

Regulators can be supplied with gauges.

Below ranges are available:

0-4 bar / 0-10 bar / 0-25 bar

- case diameter 63 mm
- internals ss 316
- bottom connection 1/4" NPT

Mounting

The regulator can be mounted in every position (horizontal / vertical).

For regulators installed outdoors, make sure that rain cannot enter the springhousing or mount it drainable.

Springloaded Pressure Regulator

Model – GRT40S-16

Connections

The regulator has threaded connections, designed for compression fittings.

Line connections

NPT threads according to ANSI B1.20.1

BSPP threads according to ISO 228-1

BSPP ports according to ISO 1179-1

Design pressure

The design pressure applies for inlet and outletside.

Temperature

The general temperature range of the regulator is -50 / 200 °C, but is often limited due to the used sealing materials.

NBR	seat / seals	- 35 / 130 °C
FKM	seat / seals	- 20 / 200 °C
EPDM	seat / seals	- 50 / 120 °C

Typenumber explanation

Example : GRT40S - 16N3 - SSNN

model	design pressure	connections	adjustable	material	seat	seals	options
GRT40S	16 : 16 bar	N : 1 1/2" NPT B : 1 1/2" BSPP	1 : 0-1 bar 3 : 0-3 bar	SS SS 316L	N NBR	N NBR	
					nitrite	nitrite	
					V FKM	V FKM	
					viton	viton	
E EPDM	E EPDM						

xx codes for special option

All regulators are marked with a typenumber, a drawingnumber and a unique serialnumber. Dutch Regulators stores the exact configuration of the regulator in the serialnumber.