

Domeloaded Pressure Regulator

Model – GRT50D

Description

The GRT50D domeloaded pressure regulator reduces the supply pressure on the inlet side to a controlled pressure on the outlet side.

Specifications

Inlet pressure	50, 280 or 420 bar
Adjustable	0-280 bar
Connections	2" BSPP
Seat diameter	22,5 mm
Cv / Kv	Cv 10 / Kv 8.8

Fluids

This pressure regulator is suitable for gases and liquids.



Materials

The regulator is made out of barstock stainless steel material.

Body	ss 316L
Dome	ss 316L
Valve	ss 316L
Seat	PCTFE, PEEK or rubber
Valve spring	ss 316
O-rings / diaphragm	NBR, FKM or EPDM

Other materials available on request.

All metal parts are marked with a traceable batch number. Material certificates are available on request.

Technical details

- all parts cleaned and degreased
- leak-tight seat design
- all regulators tested before delivery

Standards

- | | |
|-------------------|---|
| • EN 12516 | - design |
| • EN 12266-1 | - testing |
| • PED 2014/68/EU | - CAT I (optional CAT II) |
| • ATEX 2014/34/EU | -  II 2G |

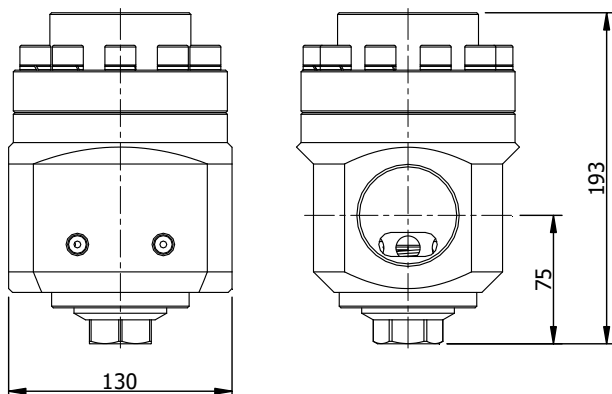
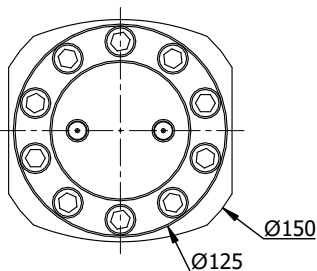

Domeloaded Pressure Regulator

Model – GRT50D

Options

Many options are available. The most requested options are mentioned below.

Materials

Regulators can be produced in higher graded materials than stainless steel 316L.

Seals

Regulators can be equipped with FFKM + PTFE seals. Other compounds for higher or lower temperatures are available.

NACE - MR 0175

All wetted parts of the regulators can be supplied according to NACE MR 0175, including Inconel X750 valvespring and a NACE report.

Spare parts

Spare parts kit is available for the regulator. Mention the serial number in case you need spare parts for existing regulators.

Adjusting the regulator

The regulator comes standard with two 1/4" NPT dome connections. The setpressure of the regulator equals to the pressure in the dome.



Dependency

Character of the regulator is "dependency". The set-pressure will increase, when you have a decreasing inletpressure.

Dependency ratios are listed below.

- range 0-280 bar - 1:400 without pilot regulator

Dependency ratio is influenced by the mounted pilot regulator.

The balanced valve has a positive effect towards dependency.

Flow

The regulator has good flow performance over the complete range. Ask for advice if this regulator is the best choice for your application.



Pilot regulator

The regulator can be supplied with a mounted pilot regulator. The pilot regulator provides the controlled pressure in dome.

External feedback

The pilot regulator can be supplied with an external feedback from the outlet of the main regulator, back to the pilot regulator. The external feedback improves the performance of the regulator.

The external feedback option is available for design pressures up to 50 bar.

Domeloaded Pressure Regulator

Model – GRT50D

Internals

The internals of the regulator are important for the performance. The different internals are mentioned below.

Diaphragm sensing

Diaphragm sensed for all ranges.

Rubber or plastic seated

Rubber seats for design pressure up to 50 bar.
A rubber seat is less sensitive to dirt.

Plastic seats for design pressure above 50 bar.
PTFE recommended and seals easy.
PEEK recommended for liquid and high temperatures.

Valvespring

The valvespring gives high spring force to ensure seat-tightness.

Gaugeports

The regulator has standard two 1/4" NPT gaugeports to measure the inlet and outlet pressure.

On request it is possible to have additional gaugeports.

Gauges

Regulators can be supplied with gauges.

Below ranges are available:

0-4 bar / 0-10 bar / 0-25 bar / 0-60 bar / 0-160 bar / 0-400 bar

- case diameter 63 mm
- internals ss 316
- bottom connection 1/4" NPT

Section view

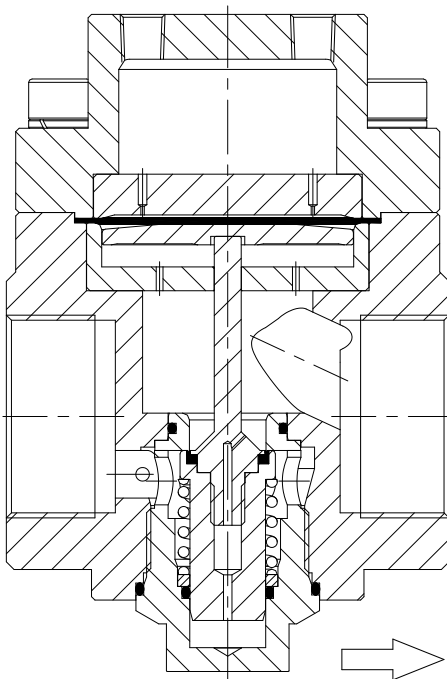

Section view of:
GRT50D-50B50-SSNN

Mounting

The regulator can be mounted in every position (horizontal / vertical).

For regulators installed outdoors, make sure that rain cannot enter the springhousing or mount it drainable.

Domeloaded Pressure Regulator

Model – GRT50D

Connections

The regulator has threaded connections, designed for compression fittings.

Line connections

BSPP threads according to ISO 228-1

BSPP ports according to ISO 1179-1

Dome connections

The regulator has two 1/4" NPT dome connections.

Design pressures

The design pressure applies for inlet and outletside.

The model with a 420 bar design pressure has a design pressure on the outletside of 280 bar.

Seat materials

The seat materials are related to the design pressure.

NBR, FKM or EPDM design pressure up to 50 bar
PCTFE or PEEK design pressure above 50 bar

Depending on temperature or special wishes, the seat material could be different as mentioned above.

Temperature

The general temperature range of the regulator is -50 / 200 °C, but is often limited due to the used sealing materials.

PCTFE seat	- 50 / 60 °C
PEEK seat	- 50 / 200 °C
NBR seat / seals	- 35 / 130 °C
FKM seat / seals	- 20 / 200 °C
EPDM seat / seals	- 50 / 120 °C

Typenumber explanation

Example : GRT50D – 50B50 – SSNN – PO

model	design pressure	connections	adjustable	material	seat	seals	options
GRT50D	50 : 50 bar	B : 2" BSPP	X : 0-X bar range depending on the mounted pilot regulator	SS SS 316L	N NBR	N NBR	PO pilot operated
	280 : 280 bar				nitrite	nitrite	
	420 : 420 bar				V FKM	V FKM	EF external feedback
	(280 bar for outlet side)				E EPDM	E EPDM	
					K PCTFE		
					kel-f		
					P Peek		xx codes for special option

All regulators are marked with a typenumber, a drawingnumber and a unique serialnumber. Dutch Regulators stores the exact configuration of the regulator in the serialnumber.